

Contents

Introduction	1
Installation	3
Dimensions	4
Power Requirements	5
Phantom Power	6
Output Level Control	6
Amplifier Controls	7
EMI Filter Components	8
Rear Panel Views	9
Connector Details	10
Connector Details Continued	11
Specifications	12
Service Information	13
1081 Recall Sheet - Horizontal Module	14
1081 Recall Sheet - Vertical Module	15

Introduction

The 1081 channel amplifier was first produced in 1972 to provide the mic/line-amp and EQ sections in Neve consoles such as the 8048. A look through the credits on today's top selling CDs will reveal that these vintage consoles are still widely used to great effect and that the 1081 module has become a hugely popular design classic. This is why AMS Neve have resumed production of the 1081, using the original components and construction methods.

In situations where the fader connection is not used (most Neve 45 series consoles) then there should be no gain adjustment necessary the modules leave the factory calibrated for this application.

In situations where a fader or a potentiometer connection is used (such as in both AMS Neve racks AM3630 & AM3631), then the internal 5K1 resistor mounted between pin E (0v) and pin K (fader send) of the module back connector should be disconnected and replaced by the external potentiometer / fader.



Final gain adjustment should then be made with the modules fitted to the rack. Each 1081 module has an adjustable pre-set potentiometer on its rear panel.



When mounted in the AMS Neve rack, these pre-sets are accessed by removing the rack rear panel and can be adjusted through the rear connector mounting panel.



The gain should be adjusted using the Line input with the sensitivity switch set to 0dB and the output level controls set fully clockwise.

Apply a 0dBu 1 kHz sine wave to the Line Input XLR and adjust the pre-set to give 0dBu at the XLR output connector, normally loaded into the appropriate input impedance of the following equipment.

Gains are now fully calibrated and the rear panel should be replaced.

Installation

The 1081 is available as a stand-alone module, or in a choice of two housings that provide power supply, phantom power switching for each module and connectors for balanced inputs (mic and line) and outputs:

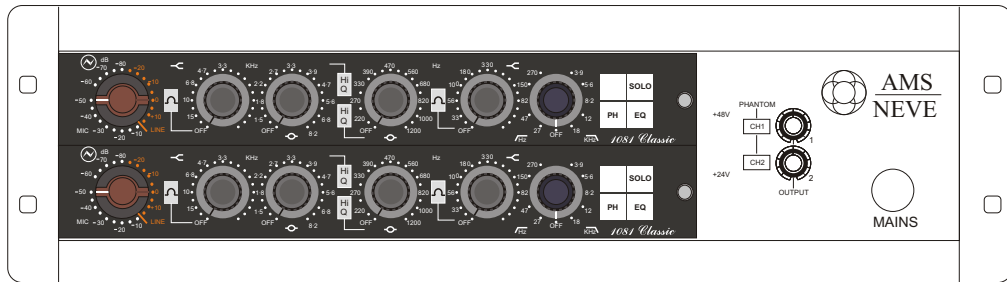

The 3U rack houses two modules mounted horizontally in a 19" rack-mounting unit. The rear panel has XLRs for transformer balanced I/O and a 25-way 'D'-type connector for solo and spare switch contacts and unbalanced outputs plus an IEC connector for mains power.

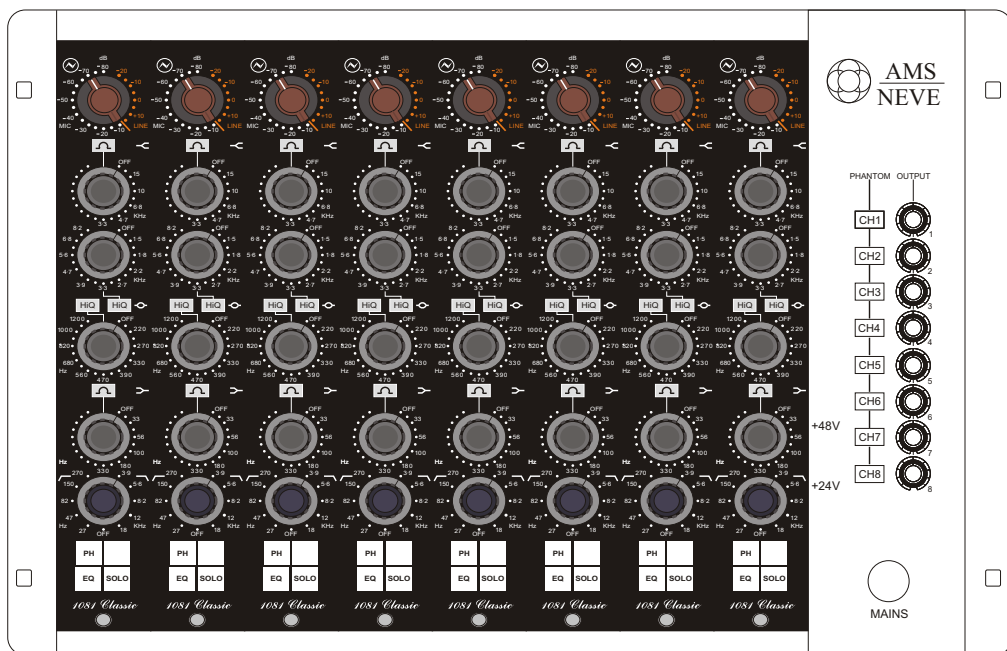

The 7U rack houses 8 modules vertically in a 19" rack-mounting unit. The rear panel has XLRs for transformer balanced I/O and a 25-way 'D'-type connector for solo and spare switch contacts and unbalanced outputs plus an IEC connector for mains power.

Dimensions

Stand-alone Module

Dimensions: Front panel 45mm x 305 mm (1.8 inches x 12 inches).
Approx 300mm (12 inches) deep behind the front panel.

Approx. Weight: 3kg (6.6 lbs)

Rack Data

19" Rack Mounting	U	Depth mm (inches)	Height mm (inches)	Approx. Weight kg (lbs) *
2 Module Version	3	400	134 (5¼)	17 (37) *
8 Module Version	7	400	311 (12¼)	46 (101) *

* Fully populated rack

The 7U unit is heavy (over 20kg) and should be handled by two persons.

Power Requirements

	3U	7U
Rated Voltage	100-230V AC	100-230V AC
Rated Frequency	50-60 Hz	50-60Hz
Rated Current	0.5A Max	0.8A Max
Surge Current (In Rush) Cold	31.0A	31.0A
Surge Current (In Rush) Hot	33.0A	33.0A
Earth Leakage Current	Approx 1.2mA	Approx 1.3mA
Warning for High Earth Leakage Current Required	NO	NO
Primary Protection Fuse:		
Operating Voltage	100-230V AC	100-230V AC
Fuse Rating and Type	T1.6A H 250V 20mm x 5mm CERAMIC	T1.6A H 250V 20mm x 5mm CERAMIC
Location	IEC Mains connector	IEC Mains connector
Secondary Protection Fuse:		
Output Voltage	24V DC	24V DC
Fuse Rating and Type	T 1.0A L 250V 20mm x 5mm GLASS	T 2.0A L 250V 20mm x 5mm GLASS
Location	F1 on SZN825-058	F1 on SZN825A058
Output Voltage	48V DC	48V DC
Fuse Rating and Type	T 500mA L 250V 20mm x 5mm GLASS	T 500mA L 250V 20mm x 5mm GLASS
Location	F2 on SZN825-058	F2 on SZN825A058

	Stand-alone 1081 Module
Power	192mA at 24V DC. Negative Earth

Mains Supply (rack units)

The power supply unit is a universal input type therefore no mains operating voltage setting is required.

The mains switch on the front panel of the 3U and 7U rack units is non-illuminating.

The CH (chassis) and 0V Link should be connected or instability may result.

Mains Fuse (rack units)

The mains fuse is located in the IEC mains input connector on the rear of the 3U and 7U rack units.

Secondary Protection Fuses (rack units)

Secondary protection fuses for the 24V and 48V supplies are located behind the front panel on the power supply filter PCB SZN825-058 in both 3U and 7U rack units.

DC Power Supply Indicators (rack units)

The red LED on the front panel of both 3U and 7U rack units indicates +24V power healthy when illuminated.

The green LED on the front panel of both 3U and 7U rack units indicates +48V power healthy when illuminated.

Phantom Power

Phantom power can be supplied to each module by pressing the phantom power switch on the front panel of the 3U or 7U rack. The LED in the switch will illuminate confirming that phantom power is supplied.

Output Level Control

Each channel has an independent Output Level Control. The control is post-input, post-EQ and pre-output. This control allows the input and EQ to operate at a higher level and then for the signal to be returned to a normal operating level at the output.

When the Output Control is fully clockwise the output gain is unity. The output is 10dB down with the control in the mid-position.

Amplifier Controls

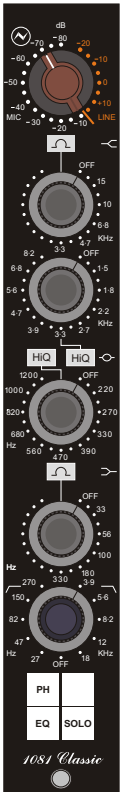

- H.F. Controls: 5 switched frequencies, shelving or peaking curve, continuously variable 18dB cut or boost.
- H.F. Presence: 10 switched frequencies with continuously variable 18dB cut or boost, high or low Q selection.
- L.F. Presence: 10 switched frequencies with continuously variable 18dB cut or boost, high or low Q selection.
- L.F. Controls: 5 switched frequencies, shelving or peaking curve, continuously variable 18dB cut or boost.
- H.P. Filter: 5 switched frequencies with slope of 18dB per octave.
- L.P. Filter: 5 switched frequencies with slope of 18dB per octave.
- PH Button: Gives 180° phase change at the balanced output.
- EQ Button: Selects equalisation in or out of circuit.
- SOLO Button: Selects channel unbalanced output and closing switch contact.
- Spare Button: Switches external device as required.

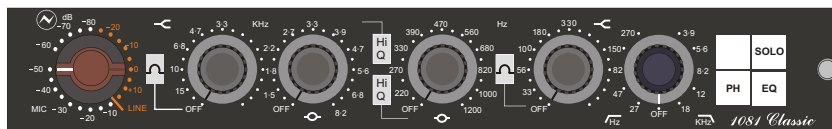

EMI Filter Components

Jumpers may be fitted on the SUN870-081 I/O boards to allow the EMI filtering (three terminal capacitors and common mode inductors) to be 'removed' from the signal path. This may be desirable for those seeking sonic purity. However it must be noted that the immunity of the product to external RF fields could suffer, and if this is the case then the jumper links should be removed.

The individual 1081 modules are offered for inclusion in the customers own housings. As such no claim is being made regarding the immunity of these units. This will be principally governed by the type of cabling, connectors and enclosure used. The use of screened cables and connectors is recommended for all connections. Tests have shown that no problems with emissions as defined in EMC standards should be present with these units.

Modules In Transit

Please note that the designs of the AMS Neve classic modules and racks are to the original Neve specifications and are not designed to withstand transit. Should you wish to move the rack from one location to another (for example shipping to another studio location or returning the rack to a repair center for servicing), please remove all installed modules from the rack and package the rack and each module separately in packaging suitable to withstand the intended transit. If modules are installed in a rack while in transit, damage to the internal edge connectors may occur

Rear Panel Views

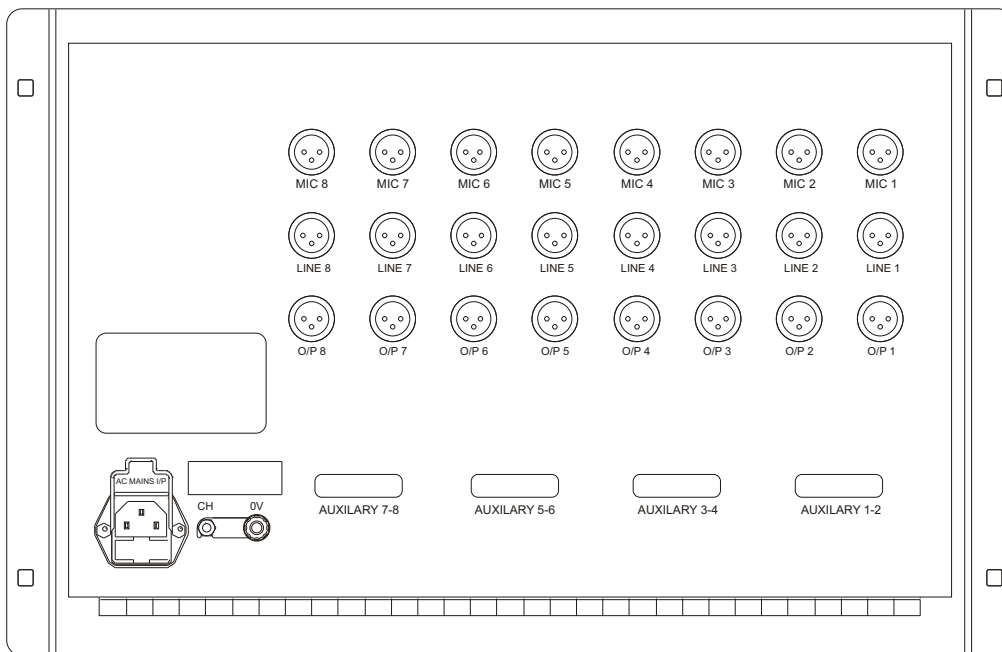
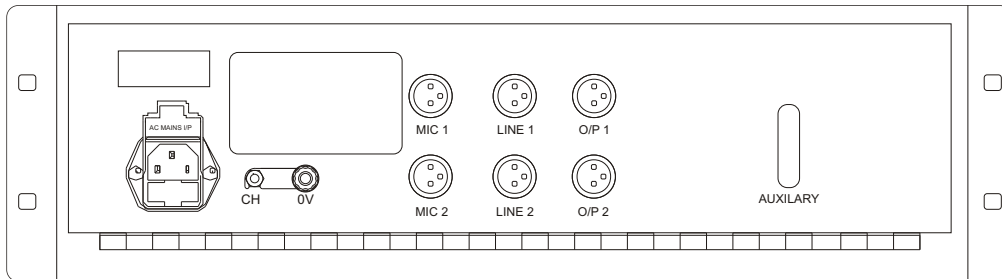

Connector Details

1081 Stand-alone Wiring to 18 way Free Plug

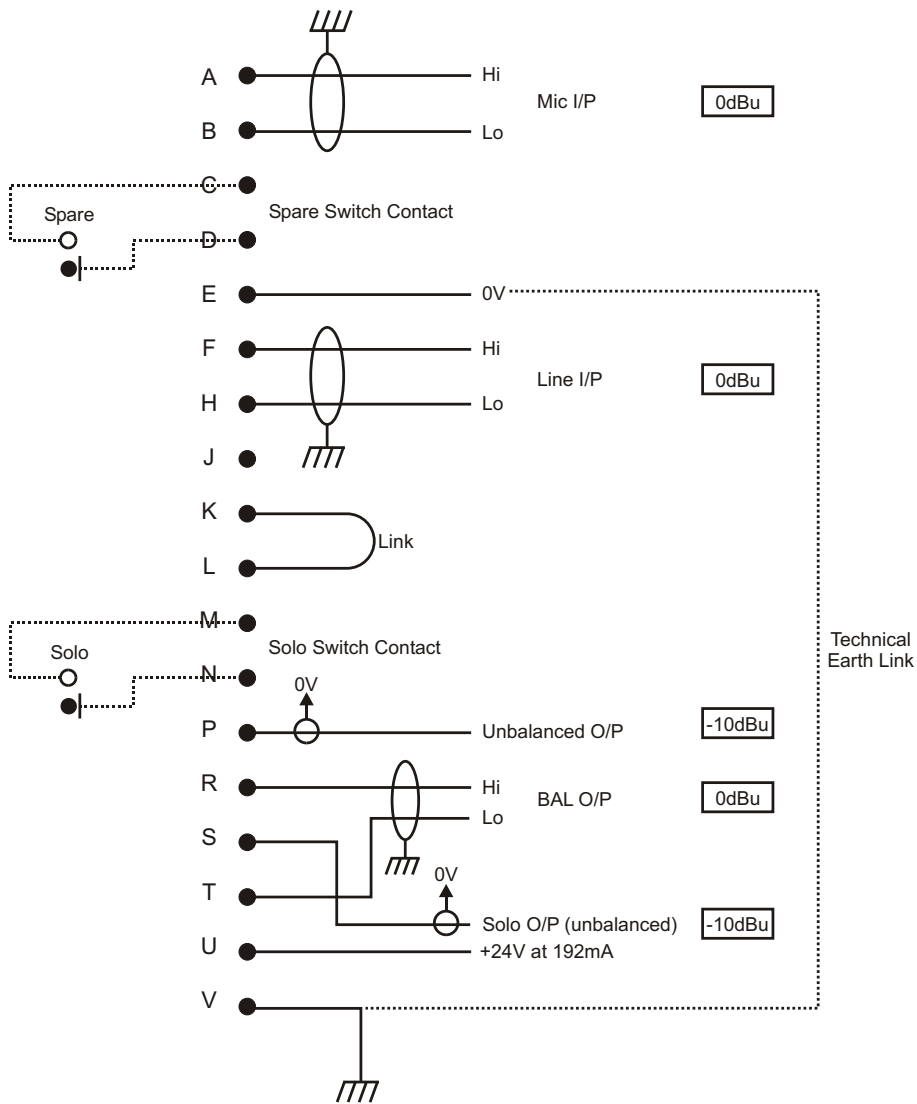

Connector Details Continued

Rear of 1081 2 Module (3U) and 8 Module (7U) Racks 25 way D Auxiliary and XLR Wiring

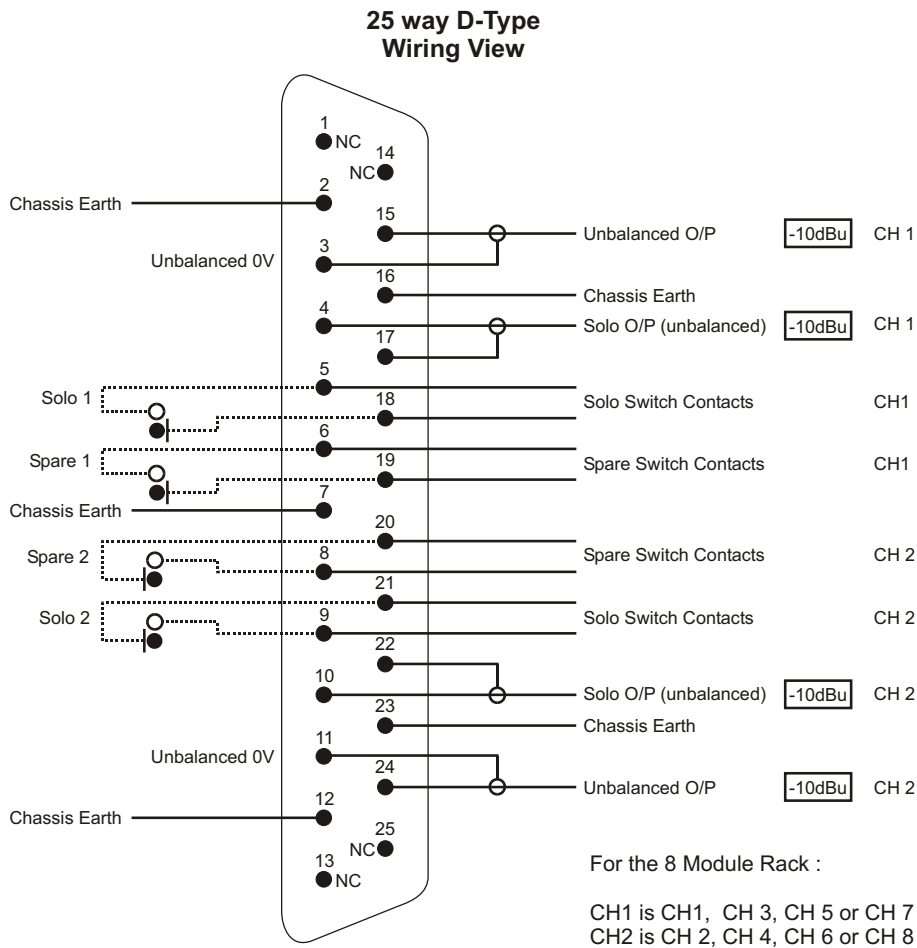

XLR Wiring View

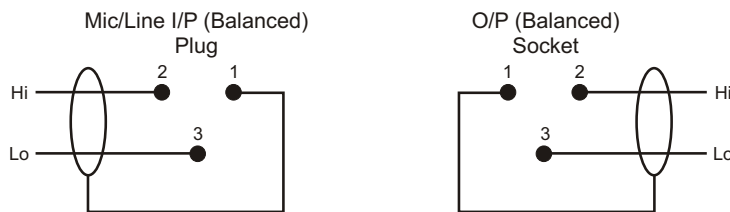

Specifications

Microphone Input:	Zin 300 or 1200 ohms switched, gain +80 to +10 dB in 5dB steps.
Line Input:	Zin 10k ohms bridging, gain +20 to -15dB in 5dB steps. Both inputs are balanced and earth-free.
Outputs:	Max +26dB into 600 ohms. Zout 75 ohms $\pm 5\%$ @ 1kHz, balanced and earth-free. An unbalanced output 8dB below the level of the balanced output is also provided.
Distortion:	Not more than 0.07% for +20dBm output from 50Hz to 15kHz.
Frequency Response:	± 0.5 dB from 20Hz to 20kHz. -3dB at 7Hz and 35kHz.
Noise:	Output noise better than -42dBm from Zin 1200 ohms and -80dB input, giving an equivalent noise of -125dBm referred to 600 ohms input impedance fed from 100 ohms. Output noise better than -80dBm at all line input levels.

Service Information

Parts List index

PL31081- Channel Amplifier Horizontal and Vertical module versions:

PL31081-C	Channel Amplifier
PL10306-C	Dual Voltage Follower
PL10312-C	Channel Amplifier Motherboard
PL10338-C	High Gain Amplifier
PL10340-C	Output Amplifier
PL20046	Sensitivity Switch
PL20047	Treble Switch Assembly
PL20048/4	Upper Presence Switch Assembly
PL20048/5	Lower Presence Switch Assembly
PL20049	LP/HP Filter Switch Assembly
PL20050	Bass Switch Assembly

AM3631 - 3U Rack:

AM3631	2 CH 1081 Mainframe Assembly Detail
SZN825-058	PSU Filter PCB
SSN818-036	0V Stud Filter PCB
SUN870-081	2CH I/P O/P Backplane
SYN824-128	2 Switch Phantom Power PCB
NN3726	Chassis Cable Assy

AM3630 - 7U Rack:

AM3630	8 CH 1081 Mainframe Assembly Detail
SZN825A058	PSU Filter PCB
Same as the 3U Rack	

1081 Recall Sheet - Horizontal Module

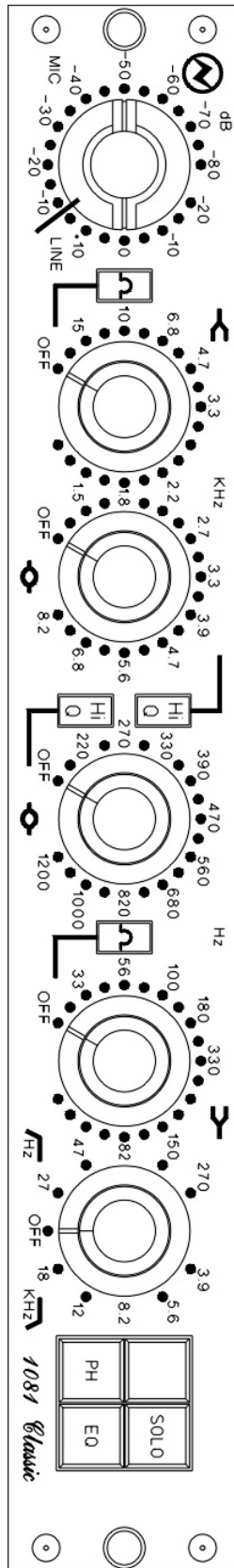

1081 Recall Sheet - Vertical Module

